

ATG ACCESS

ATG Access

Cityscape Gate



Many gate products are industrial in appearance and are inappropriate for use in pedestrianised areas. The Cityscape gate is stylish, smooth lined and pedestrian friendly as well as being immensely strong.

The Product

Having been successfully tested to the PAS 68 standard, arresting a 7500kg truck travelling at 40mph, it is a valuable addition to our proven high security product range.

It is installed with a minimum of disruption using our shallow mount technology, and the product is light in weight due to its construction; this is achieved through the use of synthetic materials and state of the art design.

The Cityscape gate is available in brushed Stainless Steel or coated finishes and can span 4m to 6m, it may be specified as right or left hand hinging and can be opened in either direction.

The Cityscape Gate may be secured by a manual locking mechanism if required.

Alternatively, securing the gate may be achieved through hydraulic operation. When this option is specified the gate can be locked/unlocked remotely.

The Application

The Cityscape Gate is an aesthetically pleasing solution designed to allow vehicular access on an irregular basis. This product is ideally suited to sites where there are few traffic movements. Users with high traffic volume will benefit from our range of fully automatic products.

The Benefits

- Impact test in accordance with BSI PAS 68
- Low maintenance requirements
- Full installation service or supply only
- Manufactured in the UK
- Proven innovative product and technology
- Anti-Attack hardware
- Ease of installation
- Cost effective installation (up to 70% less concrete)
- Lightweight but extremely strong
- In a brushed Stainless Steel finish, a high grade of stainless steel is used to provide a great quality finish
- When the painted finish is specified, the gate is still manufactured from Stainless Steel, albeit a lower grade. This Stainless Steel still ensures minimal corrosion whilst maintaining the great aesthetics of the product for years to come with minimal maintenance

www.atgaccess.com

www.atgaccessinc.com



ATG Access Cityscape Gate

Characteristics

Product	Diameter	Height	Wall thickness	Finish	Foundation Depth
Cityscape Gate	355mm (End Posts)	End Posts: 1530mm	Confidential	Galvanised ground elements, RAL colour over Stainless Steel, or brushed stainless steel.	400mm Including finishes (112mm finish is also available)

Technical specifications

Testing Criteria:	BSI PAS 68 : 2010
Vehicle weight:	7500kg
Vehicle speed:	64km/h (40mph)
Full PAS 68 Designation:	7500/64/90:1.09/2.40

Options and Extras

- Latch Post which enables the gate to be locked in an open position
- RAL colours available

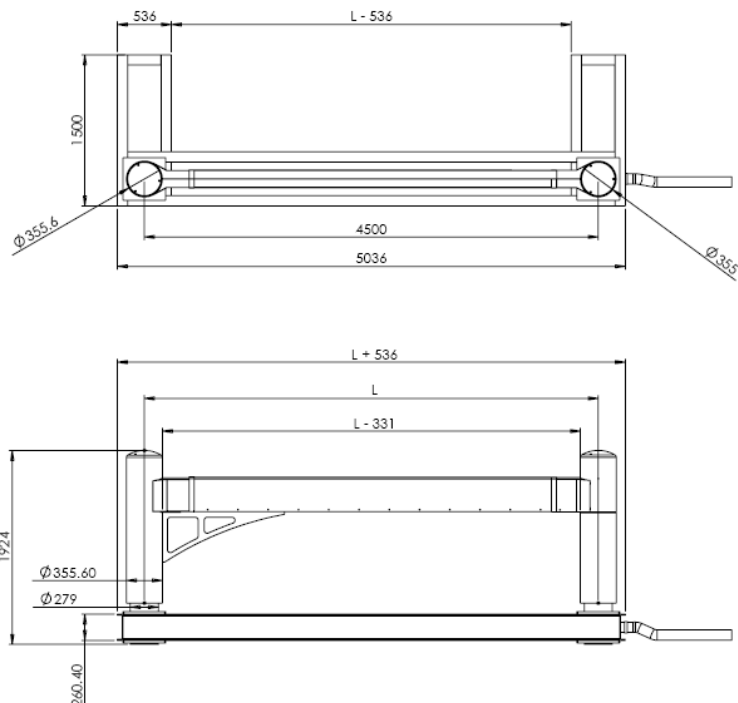

We can produce a written evaluation, in the form of a quotation, and provide drawings or photographs based on your requirements.

All details correct at time of going to press, ATG Access reserves the right to modify specifications, design, operating conditions or any other details without notice

ATG Access Inc

402 Mckinney Parkway
Lillington
NC 27546
USA

Tel: + 1 910 814 5200
Fax: + 1 910 814 5299

ATG Access Ltd

CoBaCo House
North Florida Road
Haydock Industrial Estate
Haydock

Merseyside
WA11 9TP
UK

Tel: 08456 75 75 74
Fax: 08456 75 99 55