



ATG ACCESS

ATG Access

Rapid Deployable Surface Mount



The ATG Access Rapid Deployable Surface Mount Bollard is the world's first impact tested surface mounted bollard system which requires no ground pinning and provides PAS68 certified protection.

Installation and removal of the product is straightforward and almost instant, and it can be reused when heightened security measures are needed. Ground surfaces are unharmed as no bolts are required. It is simply the best temporary, pedestrian permeable security solution available.

The Product

The ATG Access Rapidly Deployable Surface Mount Bollard System has been designed by our development team to a brief for a specific requirement. The original brief called for a system that could be pinned to the ground, and whilst it may have seemed the most obvious approach, our engineering department considered that this would significantly limit the usability in real world scenarios. This is because the integrity of the ground surface to be used may not be consistent, and authorities would most likely be reluctant to have surfaces damaged when a temporary solution is installed.

Due to the unique way this bollard system is installed it provides PAS68 certified protection via the simple use of an anchor point at each end of an array of bollards. We can offer site specific anchoring solutions if these are required. The system has also been tested in conjunction with the Hesco fence anchoring system. When used with this system no pins at all are required. This means that you can quickly and easily deploy these bollards safe in the knowledge that you are not compromising on protection, and you are not damaging the pavement surface.

The Application

With rapid deployment capability for temporary events this bollard system offers a short to mid-term solution for almost any perimeter security brief. We are currently in the process of testing this system as a buried solution that would only require a surface depth of less than 75mm, easily transforming the short term solution into a more permanent one if required.

The Benefits

- Impact tested in accordance with BSI PAS 68:2010
- The bollards may be deployed (installed) at a rate of 6 bollards every 10 minutes
- Temporary or permanent barrier with superb pedestrian permeability
- Can be integrated with a Hesco Bastian fence System.
- The bollards may be temporarily removed to allow access to underground services
- Full installation service or supply only
- Matches static, lift-out, manually retractable, and shallow mount bollards
- Manufactured in the UK
- Proven innovative product and technology
- Can be used to provide a long term permanent solution where no depth is available for more traditional foundations

Characteristics

Product	Diameter	Height	Wall thickness	Finish
Rapid Deployable Surface Mount	203mm	1000mm	Confidential	Galvanised, RAL colour sleeve, or stainless steel sleeve.

Technical specifications

Testing Criteria:	BSI PAS 68 : 2010
Vehicle weight:	7500kg
Vehicle speed:	48km/h (30mph)
Full PAS 68 Designation:	(Awaiting full PAS Designation)
Depth of Plate:	50mm

203mm Diameter on black or galvanised finish.

219mm Diameter on stainless steel finish or RAL colour (sleeve).

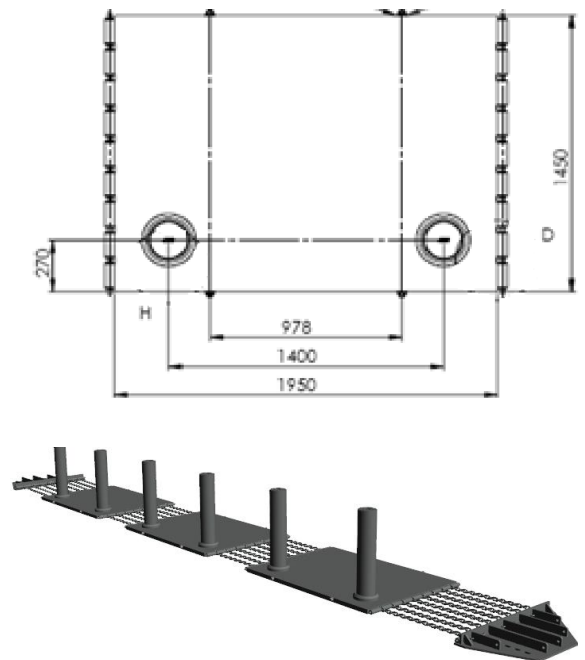
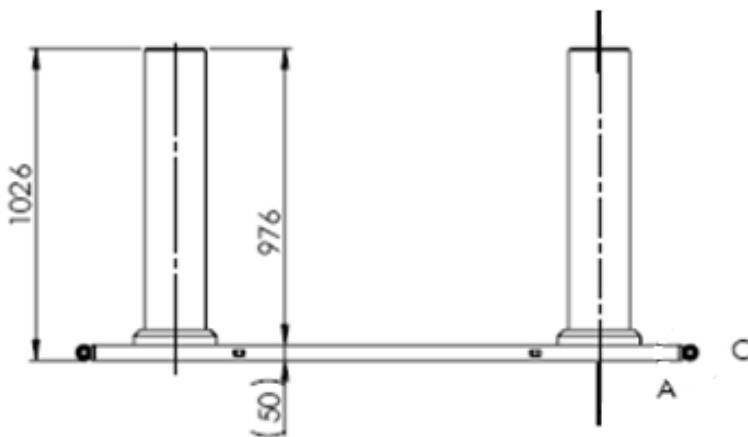

We can produce a written evaluation, in the form of a quotation, and provide drawings or photographs based on your requirements.

All details correct at time of going to press, ATG Access reserves the right to modify specifications, design, operating conditions or any other details without notice

Patent applied for.

ATG Access Inc

402 McKinney Parkway
Lillington
NC 27546
USA

Tel: + 1 910 814 5200

Fax: + 1 910 814 5299

ATG Access Ltd

CoBaCo House
North Florida Road
Haydock Industrial Estate
Haydock

Merseyside

WA11 9TP

UK

Tel: 08456 75 75 74

Fax: 08456 75 99 55