



ATG ACCESS LTD

ATG Access Ltd

SP 100



The ATG Access SP 100 is the most affordable anti-terrorism and high security bollard meeting the BSI PAS 68:2010 rating. Manually operable - no power, ducting or rebar required.

The Product

The SP 100 is our latest innovation for the high security and anti-terrorist applications. It belongs to our range of perimeter security telescopic bollards designed and tested to the PAS 68 standards.

The ATG Access range of manually operated telescopic bollards provides a secure and cost effective method of protecting premises and vehicles.

Having successfully stopped a 3500 kg vehicle travelling at 48km/h (30mph) it is well placed to meet most perimeter security requirements.

The bollard utilises internal pneumatic assistance to make this robust product easy to operate by any user. No external power is required.

The SP100 was tested in a simple concrete foundation. No rebar is required.

The application

SP 100 is ideal for commercial applications where budget is a primary constraint. This product is ideally suited to sites where there are few traffic movements. Users with high traffic volume will benefit from our range of automatic products.

The Benefits

- Impact tested to BSI PAS 68:2010 standard
- Bollard retracts down under its own weight when being lowered into the ground
- Integral lock
- Gravity operated lid
- Lift assist mechanism
- Repair and maintenance options
- Tested and proven anti-tamper locking mechanism
- All parts precision engineered and assembled by hand
- Full installation service or supply only
- Matching static bollards
- Manufactured in the UK
- Proven innovative product and technology
- Superior finish and aesthetics
- Ease of installation

ATG Access Ltd

CoBaCo House
North Florida Road
Haydock Industrial Estate
Haydock
Merseyside
WA11 9TP

www.atgaccess.com

Tel: 08456 75 75 74

Fax: 08456 75 99 55

Email: sales@atgaccess.com

Characteristics

Product	Diameter	Height	Wall thickness	Finish	Foundation Depth
SP 100	127mm or 141mm	935mm (inc. handle)	Confidential	Galvanised, RAL colour or stainless steel.	1,400mm

Technical specifications

Testing Criteria:	BSI PAS 68 : 2010
Vehicle weight:	3,500kg
Vehicle speed:	48km/h (30mph)
Full PAS 68 Designation:	V/3.500(N1)/48/90:2.8/0.0
127mm Diameter on RAL or galvanised finish.	
141mm Diameter on stainless steel finish (sleeve).	

Options and Extras

- 10 pin radial lock as standard or higher level Tubar lock options. (The Tubar lock is not available with the folding handle).
- Folding handle: Only available as standard with the stainless steel finish.
- Aesthetics: Galvanised, RAL nylon coated or stainless steel sleeve. (RAL or galvanised finish comes as standard with black T-Bar handle).

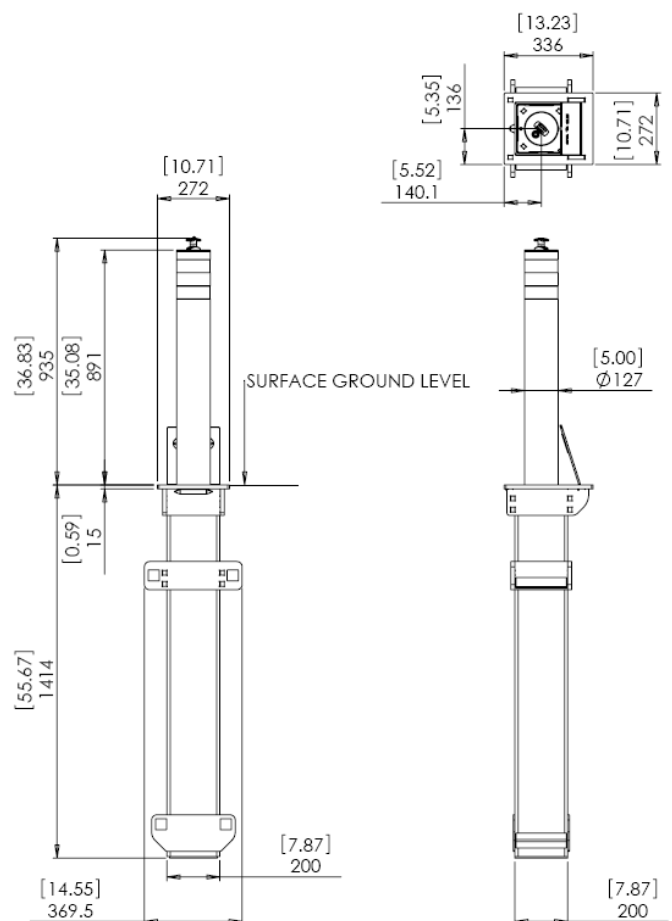

We can produce a written evaluation, in the form of a quotation, and provide drawings or photographs based on your requirements.

All details correct at time of going to press, ATG Access Ltd reserves the right to modify specifications, design, operating conditions or any other details without notice

ATG Access Ltd
CoBaCo House
North Florida Road
Haydock Industrial Estate
Haydock
Merseyside
WA11 9TP